

INSTALLATION INSTRUCTIONS

DCSS/DCCBB Doorbell Communicator

DESCRIPTION

The DCSS/DCCBB is a Doorbell Communicator that is used with the DCH4 to provide keyless entry control with the MRC88CTL. The DCSS is a stainless steel version. The DCCBB is a cool bronzed black version. Both DCSS and DCCBB mount into a single gang box.

SPECIFICATIONS

- Power: Telephone line powered (18VDC 20mA minimum)
- Dimensions:
 - Faceplate: 123.8mm x 79.4mm x 4.6mm (4.875" x 3.125" x 0.18")
 - Phone: 71mm x 46mm x 42mm (2.8" x 1.8" x 1.65")
- Shipping Weight: 0.45 kg (1.0 lbs)
- Environmental: -32C to 54C (-25F to 130F) with 5% to 95% non-condensing humidity.
- Speaker Volume: Approximately 62dB maximum @ 1m
- Ring Voltage: 25VAC RMS minimum (for auto answer)
- CPC Disconnect Time: 300ms minimum
- REN: 0.8A
- Connections: (2) gel-filled butt connectors

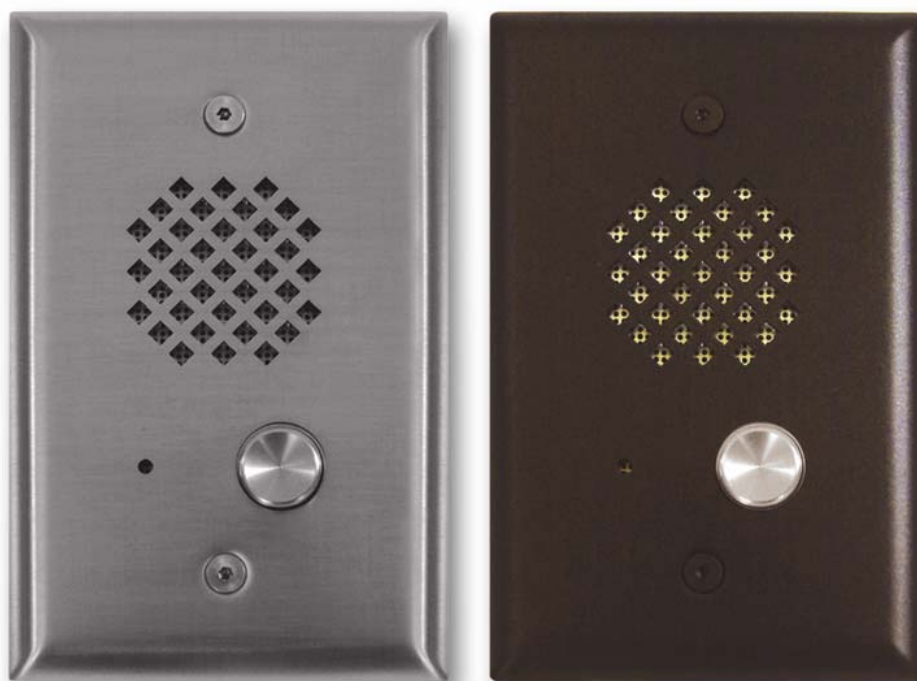

INSTRUCTIONS

The DCSS/DCCBB is designed to be flush mounted into a standard single gang Rough-In box with a minimum inside dimension of 1.70" deep x 2.00" wide x 2.84" tall.

A. New Construction Flush Mounting

Step 1. Front of box should stick out approximately ½" from front surface of wall stud (this may vary depending on the walls sheathing and siding thickness).

Caution: *Rough-In box must be mounted **LEVEL** and must **NOT** stick out beyond the front surface of siding.*

Step 2. To maintain a vapor barrier on outside wall applications, caulk around the box, filling any gaps between the box and the rough opening. Apply caulk to any holes in the box around wires, etc.

Step 3. When installing siding cut a hole just large enough for the Rough-In box opening.

Caution: *Too large of a hole can cause plate misalignment and compromise the gasket seal.*

Note: *When mounting to 4 inch or less horizontal lap siding, the unit can be mounted horizontally flush against siding or a siding mounting block can be used (recommended with vinyl siding). Contact siding installer for the correct mounting block.*

B. Old Work / Remodel Flush Mounting (Recommended Rough-In box: Allied Molded 9331)

Step 1. Make sure mounting location is free of wall studs, wires, etc.

Step 2. Place Rough-In box **LEVEL** against siding. Trace outline of box onto siding.

Note: *When mounting to 4 inch or less horizontal lap siding, the unit can be mounted horizontally flush against siding or a siding mounting block can be used. Contact your siding Installer for the correct mounting block part number.*

Note: *A siding mounting block is recommended when mounting to vinyl siding.*

Step 3. Cut a hole through the siding and wall sheathing just large enough for the rough-in box.

Caution: *Too large of a hole can cause plate misalignment and compromise the gasket seal.*

Step 4. The front surface of the Rough-In box can be mounted flush against wood siding or can be recessed and mounted flush against wall sheathing when mounting on aluminum, steel or vinyl siding.

Step 5. When mounting to 5/8 inch thick or less wall sheathing the two attached screws with wing brackets can be used to secure the rough-in box. When mounting to surfaces thicker than 5/8 inch, four standard flat head dry wall screws can be used to secure the Rough-In box through its mounting ears.

Step 6. To maintain a vapor barrier on outside wall applications, caulk around the box, filling any gaps between the box and the rough opening. Apply caulk to any holes in the box around wires, etc.

WARNING: Do not use a "Wet Location Box"

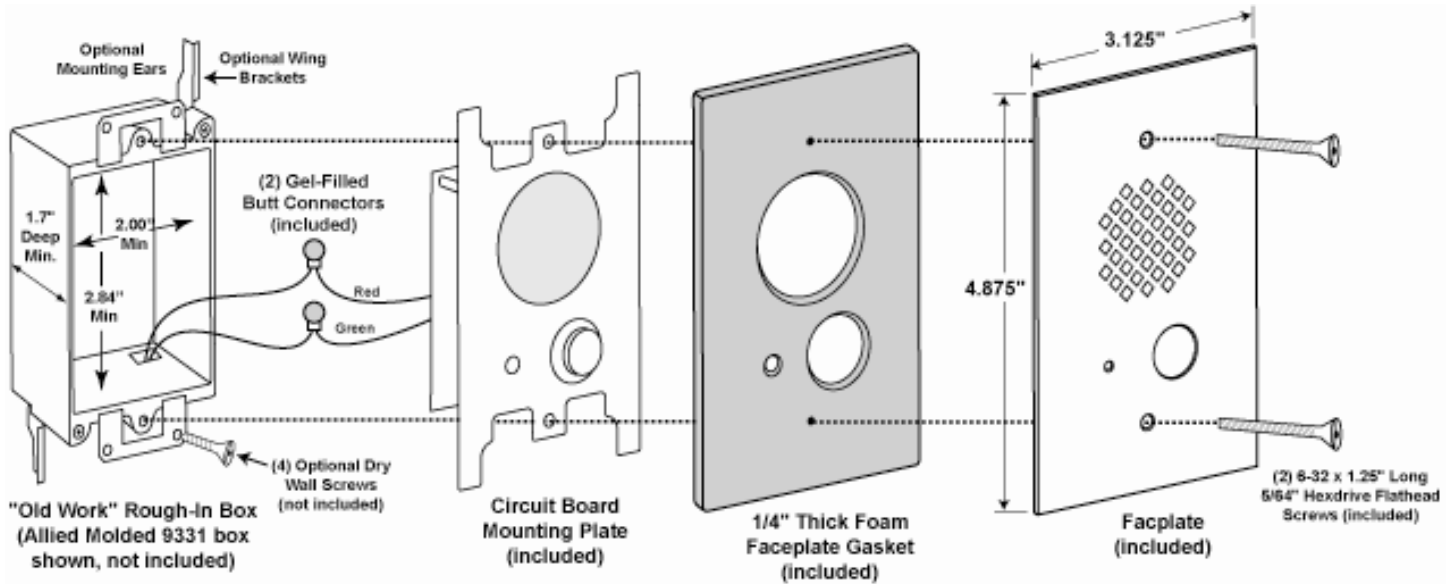

PROGRAMMING

A. Adjusting Speaker Volume

The speaker volume pot can be adjusted to increase or decrease the speaker volume to the level desired.

B. Adjusting the Microphone Volume

In certain noisy locations (background traffic, machinery or wind), the microphone volume may need to be decreased. A symptom of this is one-way talk path, in which the distant party cannot be heard over the speaker. A microphone volume pot is provided for increasing or decreasing the microphone volume.

Note: If the microphone volume is set too high or too low, one-way talk path may occur.

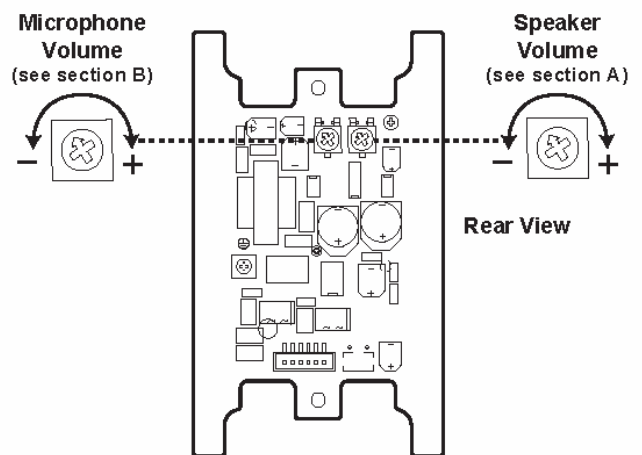

C. Call Length Time Out

This feature limits the maximum length of time that calls can be connected to 5 minutes.

D. Silence Time Out

This feature limits the length of time that calls will remain connected without voice activity to 40 seconds.

OPERATIONS

When the push button is pressed, the DCSS/DCCBB phone goes off-hook, much like a standard speaker phone. In the event that the line is busy, the DCSS/DCCBB will hang-up. The DCSS/DCCBB will also automatically hang up on CPC, silence, busy signal, return to dial tone or time out. The DCSS/DCCBB will also answer any incoming call.

FCC REQUIREMENTS

This equipment complies with Part 68 of the FCC rules and the requirements adopted by the ACTA. On the side of this equipment is a label that contains, among other information, a product identifier in the format US:AAAEQ##TXXXX. If requested, this number must be provided to the telephone company.

The REN is used to determine the number of devices that may be connected to a telephone line. Excessive REN's on a telephone line may result in the devices not ringing in response to an incoming call. In most but not all areas, the sum of the REN's should not exceed five (5.0). To be certain of the number of devices that may be connected to a line, as determined by the total REN's, contact the local telephone company. For products approved after July 23, 2001, the REN for this product is part of the product identifier that has the format US:AAAEQ##TXXXX. The digits represented by ## are the REN without a decimal point (e.g., 03 is a REN of 0.3). For earlier products, the REN is separately shown on the label. The plug used to connect this equipment to the premises wiring and telephone network must comply with the applicable FCC Part 68 rules and requirements adopted by the ACTA. If your home has specially wired alarm equipment connected to the telephone line, ensure the installation of this DCSS/DCCBB does not disable your alarm equipment. If you have questions about what will disable alarm equipment, consult your telephone company or a qualified installer. If the DCSS/DCCBB causes harm to the telephone network, the telephone company will notify you in advance that temporary discontinuance of service may be required. But if advance notice isn't practical, the telephone company will notify the customer as soon as possible. Also, you will be advised of your right to file a complaint with the FCC if you believe it is necessary.

The telephone company may make changes in its facilities, equipment, operations, or procedures that could affect the operation of the equipment. If this happens, the telephone company will provide advance notice in order for you to make the necessary modifications to maintain uninterrupted service. If trouble is experienced with the DCSS/DCCBB for repair or warranty information, please contact:

XANTECH CORPORATION, 13100 TELFAIR AVE. SYLMAR, CA 91342 (818) 362-0353

If the equipment is causing harm to the telephone network, the telephone company may request that you disconnect the equipment until the problem is resolved. Connection to Party Line Service is subject to State Tariffs. Contact the state public utility commission, public service commission or corporation commission for information.

WHEN PROGRAMMING EMERGENCY NUMBERS AND (OR) MAKING TEST CALLS TO EMERGENCY NUMBERS:

Remain on the line and briefly explain to the dispatcher the reason for the call. Perform such activities in the off-peak hours, such as early morning or late evenings. It is recommended that the customer install an AC surge arrester in the AC outlet to which this device is connected. This is to avoid damaging the equipment caused by local lightning strikes and other electrical surges.

PART 15 LIMITATIONS

This equipment has been tested and found to comply with the limits for a Class A digital device, pursuant to Part 15 of the FCC Rules. These limits are designed to provide reasonable protection against harmful interference when the equipment is operated in a commercial environment. This equipment generates, uses, and can radiate radio frequency energy and, if not installed and used in accordance with the instruction manual, may cause harmful interference to radio communications. Operation of this equipment in a residential area is likely to cause harmful interference in which case the user will be required to correct the interference at his own expense.



Xantech Corporation
13100 Telfair Avenue, 2/F
Sylmar, CA 91342

Installation Instructions, DCSS/DCCBB

© 2007 Xantech Corporation, Document #08905108C

This document is copyright protected. No part of this manual may be copied or reproduced in any form without prior written consent from Xantech Corporation.

Xantech Corporation shall not be liable for operational, technical, or editorial errors/omissions made in this document.