

INSTALLATION INSTRUCTIONS

MODEL RS232IR RS232 TO IR MODULE

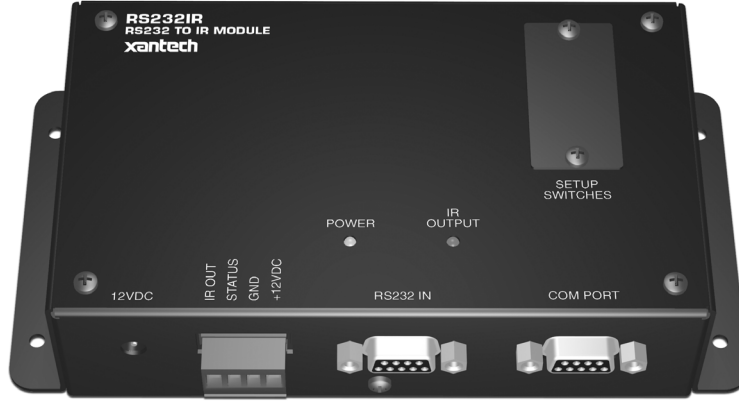

TABLE OF CONTENTS

<u>Section Title</u>	<u>Page</u>
INTRODUCTION	3
COMPUTER REQUIREMENTS	3
INCLUDED HARDWARE AND SOFTWARE ITEMS	3
HARDWARE CONNECTIONS	3
SOFTWARE INSTALLATION	4
STARTING DRAGON DROP-IR™	4
SERIAL PORT SELECTION	4
PROGRAMMING PROCEDURES	
Planning the System	4
Learning IR Commands	5
Editing and Testing IR Commands	6
PROGRAMMING THE RS232IR	
Select Base Unit.....	7
Programming IR Commands and Sequences	8
Programming RS232IR Commands to a System Controller.....	9
SAVING AND BACKING-UP FILES	10

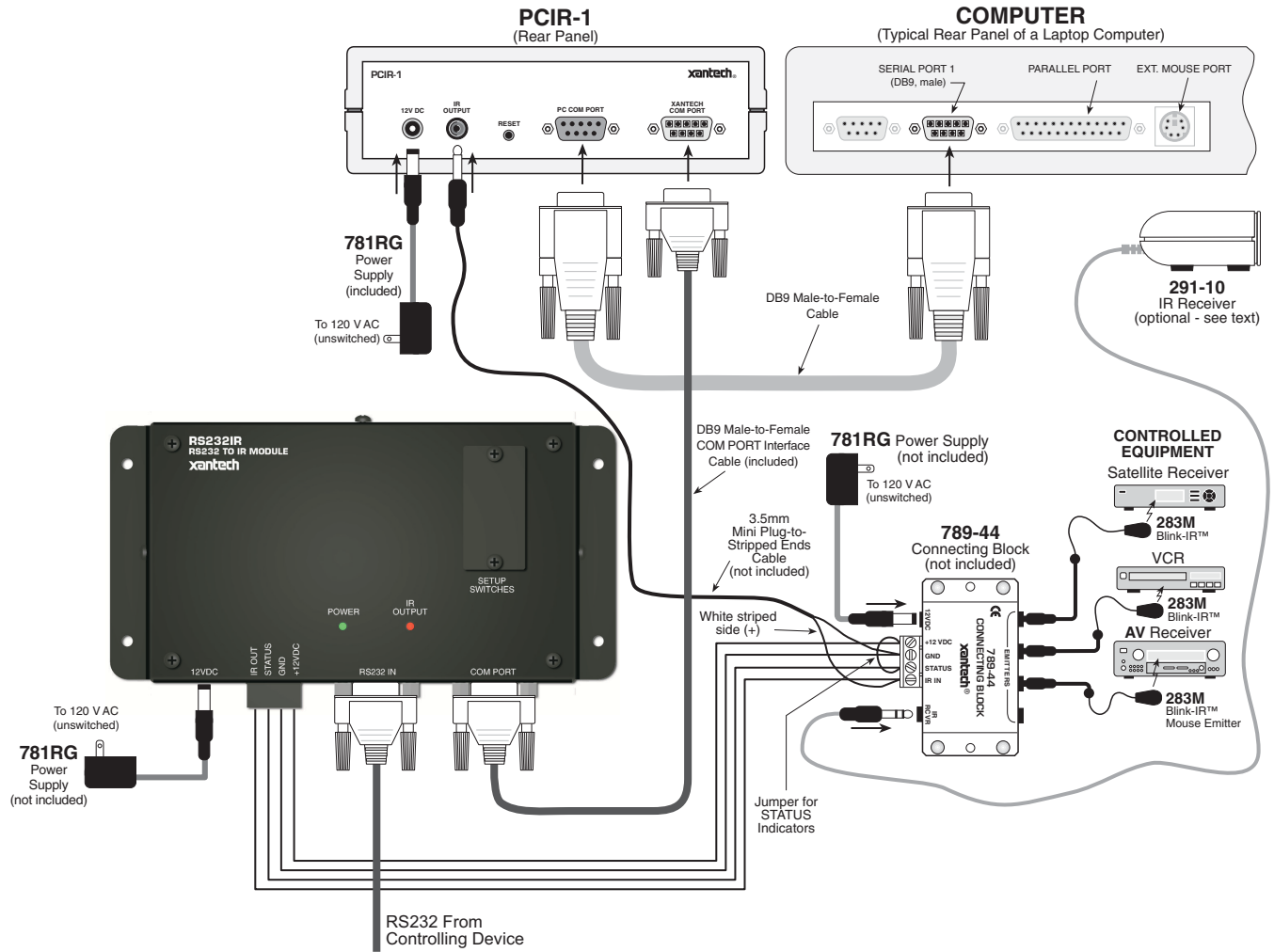

Figure 1 – Hardware Connections

INTRODUCTION

The RS232IR has the ability to send IR codes or sequences when triggered by Xantech defined ASCII Commands.

The first section of this manual will cover aspects of DRAG460 regarding setup, learning IR codes etc. The following sections will cover the particulars of programming the RS232IR.

COMPUTER REQUIREMENTS (MINIMUM)

- 486 66-MHz IBM® Compatible Computer (Pentium versions preferred)
- Windows 95/98/NT/2000/ME/XP
- 5 MB Hard Drive space (you will need more as your keypad libraries expand)
- 16 MB RAM (32 MB preferred)
- Mouse

INCLUDED HARDWARE & SOFTWARE ITEMS

To use the DRAG460 beta program, you will need the following items included with Dragon Drop-IR™. (See Installation instructions DD4 v 4.1.3 for use of other parts and connectors.)

1. CD ROM Disc. Contains the Dragon Drop-IR software, plus IR Code and Product files.
2. One DB9 Male-to-Female Cable. Connects to the Com ports on the RS232IR and a PC for programming.

HARDWARE CONNECTIONS

1. Connect all of the hardware together using the cables provided. Refer to **Figure 1**.

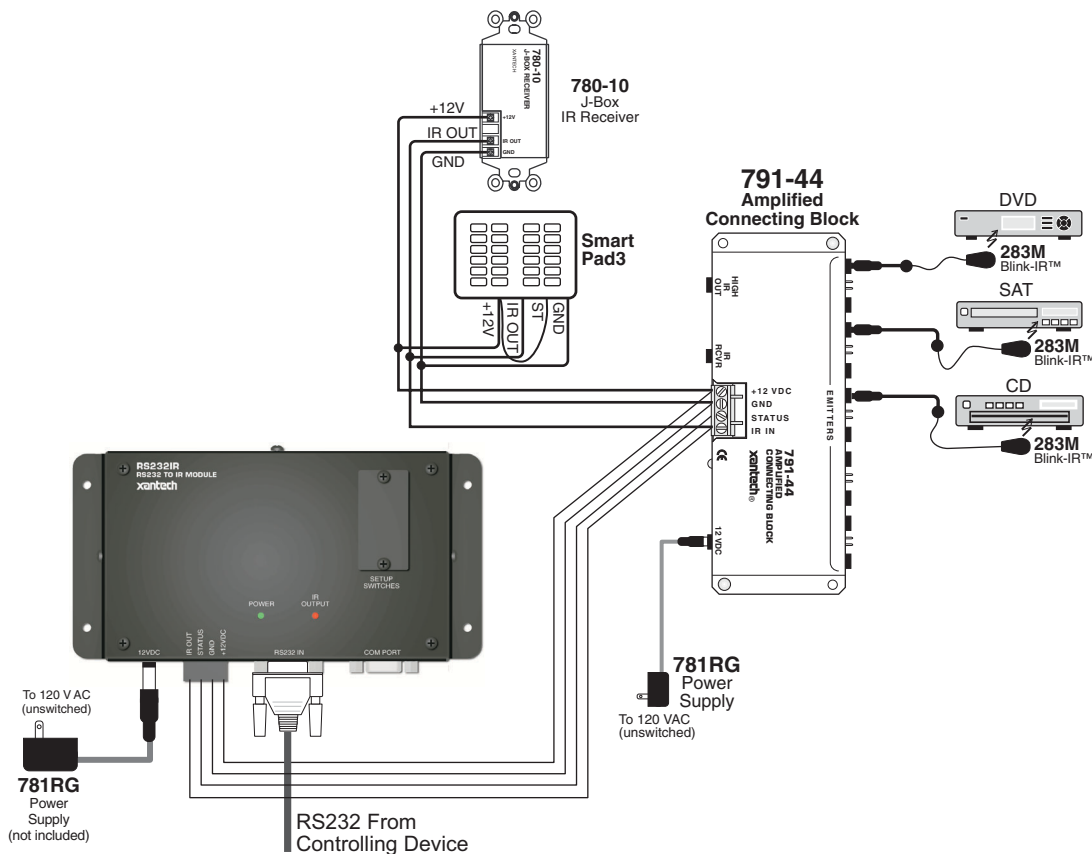

Figure 2 – Typical Basic System

2. Connect the OUTPUT of the RS232IR to be programmed to the product to be controlled to test commands. **Figure 2** shows connections to a typical basic system.

3. **Figure 1** also shows a 291-10 IR Receiver as an optional item. You could use this to test IR commands on the controlled equipment through the IR system before they are learned and programmed by Dragon Drop-IR, if programming IR.

Setup Switches

1. Write/Protect Switch. Up is 'Write', Down is 'Protect'. Must be in 'Write' position for programming. Protect position prohibits programming and protects all stored data from unintentional erasure.
2. Network Address Switch. Has no function in this product. Should be left in factory default '0' position.
3. Restore Switch. Resets unit to restart operation after errors, lockups, etc. Does not erase user programmed commands.

SOFTWARE INSTALLATION

The installation software for the Dragon Drop-IR system is included in the supplied CD ROM. Install the Dragon Drop-IR™ Software onto your hard drive as follows:

Windows 95/98/NT/2000/ME/XP

1. Insert the DRAG460 beta CD into your CD-ROM drive. If your drive has been set for auto run, a 'Xantech Welcome' menu will appear. If not, access your CD ROM with Windows Explorer and double click "autorun.exe".
2. On the Welcome menu, click Install DD460 Software.
Follow the on-screen instructions as the program installs. It takes approximately one to three minutes to complete, depending on the speed of your machine.
NOTE: For the convenience of the installer, the Dragon Drop-IR CD ROM contains a complete set of Application Notes, the Xantech Product Catalog, Factory Learned IR Codes, web site browsers and important notes. Read the Very Important Notes first, click on the desired menu item and follow the on-screen instructions.

STARTING DRAGON DROP-IR

Windows 95/98/NT/2000/ME/XP

1. Installation creates a shortcut on the desktop. Double click on the DRAG460 Shortcut or:
2. From START menu, choose Programs.
3. Select DRAG460 from the list and click on the DRAG460 Icon.
4. The program loads and opens to the Xantech Dragon Drop-IR opening screen.

SERIAL PORT SELECTION

When first launched, the Dragon Drop-IR software scans the serial ports and will display the available ports under "Preferences" in the File menu. Unavailable ports will be grayed out. Com Port 1 would normally be used, but if it is already in use, it will be necessary to use a different one. If your computer only has a USB connection, a USB to Serial Adapter (including software) can be purchased at most computer stores and is available for purchase from Xantech. (Also check with local Authorized Xantech Distributor).

Select the Com Port as follows:

1. Click "PREFERENCES" (F2) from the File menu.
2. Click on an available port, then OK.

PROGRAMMING PROCEDURES

PLANNING THE SYSTEM

Before attempting any programming, plan the system configuration first. This should include the following:

- a) Determine the brands and types of all IR-controlled components you expect to use.
CAUTION: See caution card (included) for the latest information regarding code compatibility before finalizing the system.

LEARNING IR COMMANDS

NOTE: Before starting this section, palettes created in other versions of Dragon Drop-IR can be Copied and Pasted to the PALETTE FOLDER in DRAG460 beta.

1. From the "COMPONENT" menu, click "PALLETTE EDITOR" (F3).



Figure 3 – Brands

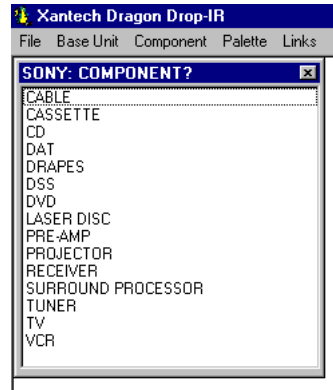

Figure 4 - Component

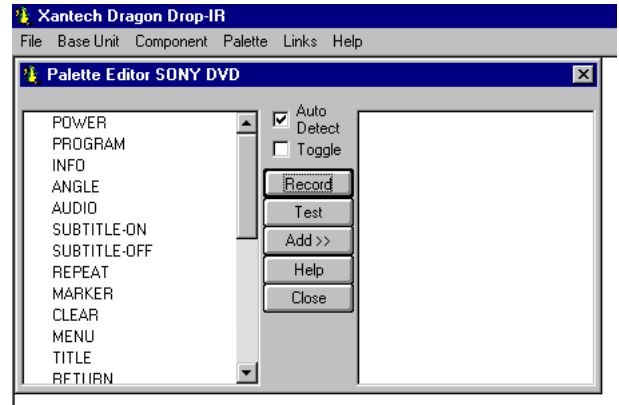

Figure 5 – Palette Editor

2. Locate and Select (single click) the desired BRAND as shown in **Figure 3** (i.e. Sony, Panasonic etc). A list of Components will appear. (See later sections for adding brands.)
3. Locate and Select (single click) the type of COMPONENT as shown in Figure 4 (DVD, SAT etc) (See later sections for adding types).
4. The Palette Editor will now be open to the "Brand" & "Component" selected. A list of FUNCTIONS for that type of component will appear as shown in **Figure 5**. (See later sections for adding functions).
5. Click on the RECORD button in the middle of the Palette Editor. The RECORD button outline will turn red. Dragon is now ready to learn the IR codes for the specific brand/component selected.

NOTE: Once in record mode, or any mode in Palette Editor, it is not necessary to select RECORD, or any other mode again, until leaving that mode.

6. Select the command from the left side of the Palette Editor (i.e. Power, Play, Stop etc.).
7. Hold the component remote about one inch from the PCIR IR Sensor on the front of the PCIR.
8. While continuing to keep the component remote about one-inch from the PCIR, press the corresponding command button on the component remote. A red asterisk (*) will appear to the left of the selected function indicating that an IR code has been learned.

NOTE: If you wait longer than ten seconds, a "NO IR RECORDED" message will appear. Click "OK" and try again.

9. Repeat steps 6 thru 8 for all of the functions to be used for that component.
10. With the PCIR connected to the Connecting Block as shown in **Figure 1**, select "TEST" in the Palette Editor. The TEST button outline will turn red.
 - a) Click on each of the command names, one-by-one, that are to be tested. A red dot will flash just to the left of "TEST" as the IR command executes.
 - b) The controlled component should respond to each command sent.(i.e. "Power" turns the component ON or OFF, "PLAY" plays the content etc.)

NOTE: Only functions with an asterisk will execute.

 - c) If a component does not respond to a command, re-learn and re-test the IR command until the component responds.

Creating Palettes

1. After Dragon has learned the commands for that Component, select "ADD>>". The ADD button outline will turn red.
2. Click on a function (i.e. PLAY) to be added to the palette. A window "NEW PALETTE" will open. Type in a file name i.e. PIONEERCD and click "SAVE".
3. "PLAY" will appear in the PIONEERCD.pal window with a red asterisk.
4. Click on all functions to be added to PIONEERCD.PAL
5. Click the "CLOSE" button on Palette Editor. Palette Editor will close. PIONEERCD.PAL will be saved to the hard drive.

- Repeat 1-10 in 'Learning IR Commands' and 1-5 in 'Creating Palettes' for all components to be used.

EDITING AND TESTING IR COMMANDS

If a brand, component or function is not found in Palette Editor, each can be added as follows:

Adding Brands

- If the brand you need is not already on the list, choose the Component menu and click on "ADD BRAND".
- Type the brand name and press enter on the keyboard or click OK.
- The new name is added and saved to the list.

Adding Components and Functions

- If the component you need is not already on the list, choose the Component menu and click on "ADD REGULAR COMPONENT".
- Type the component name and press enter on the keyboard.
- Type the name of a function for this new component in the text box and press enter on the keyboard to save the new function.
- Repeat step 3 for all functions required for the new component.
- Press "Esc" on keyboard to save and exit.
- New Brands, Components and Functions can now be selected and programmed in the Palette Editor.

Other Editing Functions

- Help.** Gives basic help information for the Palette Editor.
- Close.** Closes the Palette Editor when you have finished editing. Auto-save feature saves all IR commands and created palettes.
- To access the **Delete**, **Rename** and **New Function** attributes, right click within the list of commands. A pop-up menu showing each of the above appears.
- For **Delete** and **Rename**, right click the desired command first, then left click either Delete or Rename and follow the prompts.
- For **New Function**, right click on empty space within the list, then left click New Function. Follow the prompt. When finished, click the Close button. Any changes will be saved automatically.

Getting Source Commands From The Internet

Xantech.com

There are some IR commands that can be difficult to learn in Dragon. Xantech edits and posts some of these commands at xantech.com under Products/IR Code Libraries. (See website for listings and download instructions.) A direct link to xantech.com can be found in the "Links" option in the Dragon menu bar.

Remote Central.com

There is a second option for on line IR codes. RemoteCentral.com provides an almost unlimited resource of IR commands. The code files at Remote Central are not directly compatible with Dragon Drop-IR and therefore need to be converted for use with Xantech software.

- Click "LINKS" in DRAG460.
- Click on Remote Central Website. Your browser will open and take you to Remote Central.com.
- Click Files in Remote Central.
- Click Philips Pronto & ProntoPro.
- Click on Component CCF files.
- Scroll and click on desired brand under "Component Configurations" (CCF files).
- Click on component type (CD players, VCR's, etc.).
- From the list find a Model Number the same as your model or one similar to it. (Even model numbers considerably different than yours will usually have commands that work).
- Click on DOWNLOAD (this may take a few seconds), then select Save this file to disk, then OK.
- In the Windows 'Save As...' pop-up, Open the ccf folder within the Drag460 folder (if not already open). Click Save.
- In DRAG460, click Import CCF from the File menu.
- Find the ccf folder in which you saved the file and click on file name.

NOTE: At this point, prior to opening it, you may wish to change the file name (e.g., RCA-DSS, etc.) for easier recognition later. You may wish to do this in step 13 as well.

13. Click Open. This unzips the file and DRAG460 automatically places it in a folder within the ccf folder.
14. Click on file name, then on Open. At this point, the CCF file is converted to DRAG460 format.
15. On the pop-up (CCF Importer), type in Brand Name and Component Name (e.g., RCA and DSS).
16. Double click on the desired component type on the list of converted files on the left side of the pop-up (e.g., DSS.cnv). An asterisk (*) will appear just to the left. Click Import.
17. Click OK for addition to Brand List (if shown) and OK for addition (or merge) to a .bci file. This completes the file import to the Brand and .bci files in DRAG460.
18. At this point, or at any later date, you can choose additional component types from the CCF file (e.g., DVD, etc., if listed) by using the CCF Importer again. Simply click Import CCF from the File menu, double click on desired folder and repeat steps 13 to 16 as necessary.

PROGRAMMING THE RS232IR

SELECT BASE UNIT

With the system operating and Dragon Drop-IR open proceed as follows:

1. Choose "NEW PROJECT" (CTL+N) from the File menu. (Choose "OPEN PROJECT" (CTL+O) to modify an existing project file).
2. In the New Project window, type a file name such as joneshome and click "OPEN". The proper file extension is added automatically.
3. From the Base Unit menu, select "RS232IR".

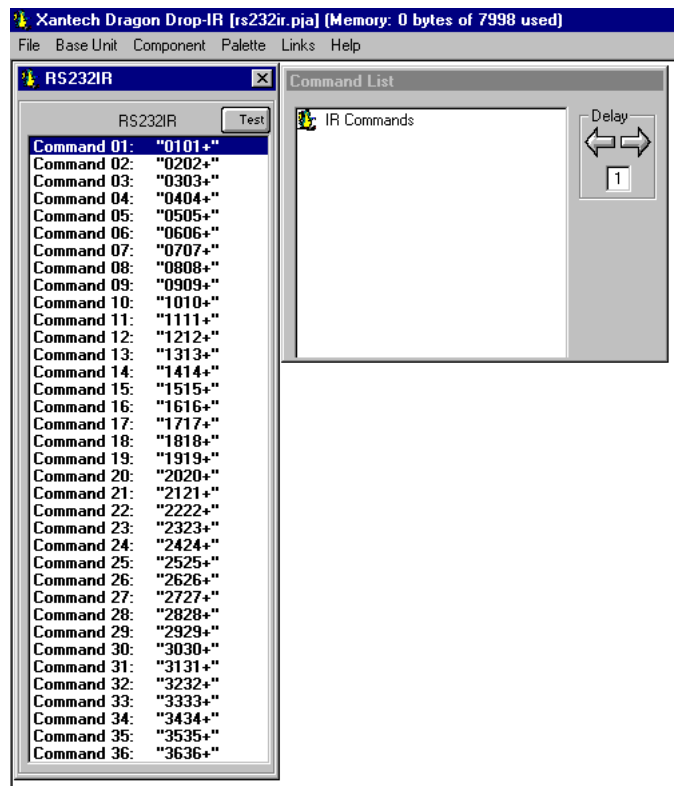

Figure 6 – ASCII Commands and Command List

4. A graphic window (RS232IR) with 36 ASCII Commands and a Command List will appear. **Figure 6.**

Selecting Palettes

- a) From the "PALETTE" menu, click "SELECT IR COMMAND PALETTE". (F4)
A list of palettes file names appears to the right with Select Palette in the title bar.

- b) Scroll the list (if necessary) and click on the filename for each palette of the components to be controlled. (e.g. pioneercd.pal, rcadss.pal, etc).
As each file name is selected, the palettes will appear side-by-side, left to right, with the filename in each title bar.

NOTE 1: The various palettes and window boxes can be moved and sized (except the virtual keypads) for ease of use.

NOTE 2: Each palette can be edited by clicking the Edit Palette bar or closed with the X button in the title bar.

PROGRAMMING IR COMMANDS AND SEQUENCES

Associating RS232 Commands with IR Control Codes

1. Select an ASCII string in the RS232 window. It will be highlighted in a blue background.
2. In the appropriate palette, click on the command to be associated to the selected ASCII string.
3. The code name (function/brand/component) for that ASCII string will appear in the Command List.
4. To remove a code from the command list, right click on the code, it will disappear, showing that it has been erased.
5. Move the 'Write/Protect' switch on the RS232IR module to the 'Write' position.
6. From the File menu, select Base Unit Transfer. The project should be transferred to the RS232IR. If the project does not transfer, check connections, **Figure 1**, and Com Port connection in 'Preferences'. Try the Base Unit Transfer again. The project should transfer.
7. Move the 'Write/Protect' switch to the 'Protect' position.

Programming Sequences

All buttons on the RS232IR can be programmed to send a single IR command or IR sequences of up to 40 commands.

1. Click the ASCII string to be programmed.
2. Open all palettes to be used in the sequence.
3. In the palettes, click on the commands in the order of the sequence to be sent.
4. The code names (function/brand/component) for that ASCII string will appear in the order selected in the command list.
5. To remove a code from the command list, right click on the code, it will disappear, showing that it has been erased.

Editing Sequences

1. The Command List can be edited by dragging and dropping any command on the list to any position on the list. Left click/hold and drag the command to be moved. As you drag upward and you want the command between two existing commands, drop it on the lower one. As you drag downward, drop it on the upper one.
2. You can delete any command on the list by Right Clicking on the command.

Timed Delays

1. Timed delays can be placed in a sequence. Click the left "<" and right ">" arrows under "DELAY" in the Command List window for the number of seconds you want (i.e. 2 = 2 seconds).
2. Double Click within the "Delay" outline. This will place the desired delay at the end of the Command List. Delays can also be dragged into the Command List to the desired position.
3. Left Click and Drag the "Delay 2 Sec" line and drop it between any two commands you have placed on the Command List.
5. Move the 'Write/Protect' switch to the 'Write' position.
4. From the file menu, select "BASE UNIT TRANSFER". The project should be transferred to the RS232IR. If the project does not transfer, check the connections, **Figure 1**, and Com Port connection in 'PREFERENCES'. Try "BASE UNIT TRANSFER" again. The project should transfer.
5. Move 'Write/Protect' switch to 'Protect' position.

Testing Commands and Sequences

From Dragon

1. With the PC connected to a PCIR, a connecting block and components as shown in **Figure 1** select the "TEST" button in the virtual RS232IR window. It will be highlighted in red.

2. In the virtual RS232IR window, click the ASCII string for the IR command to be used to trigger the IR sequence in the RS232IR.
3. The IR command or sequence shown in the Command List for that ASCII string will be sent out the PCIR IR output to the components to be controlled.
4. Make any changes to the sequence as needed.

From The RS232IR

1. With the RS232IR connected to an emitter or connecting block (as needed given the number of components to be controlled), send the RS232 trigger command to the RS232IR via a computer or system controller.
2. The RS232IR should output the proper IR commands to the components.
3. Make changes to the IR codes or sequences as needed in Dragon and transfer the project again.
4. Repeat steps 1-3 until all controls are proper.

PROGRAMMING RS232IR COMMANDS TO A SYSTEM CONTROLLER

The method of entering RS232IR commands into the device controlling the RS232IR will vary from product to product. Please refer to the Installation Instructions for the specific product to be used. Once programmed, the RS232 output of the control device should be connected to RS232 IN on the RS232IR as shown in **Figure 2**.

1. To use Command 01, enter "0101+" into the control device to be used. To use Command 02, enter "0202+".
2. Repeat for as many commands needed up to Command 36.

SAVING AND BACKING-UP FILES

Automatic Save

When working on a project in Dragon, it is automatically saved on a continuous basis. It is OK to quit a project at any time and come back to it for further work by simply clicking on "OPEN PROJECT" (Ctrl+O) from the File menu and double clicking the filename in the list.

Save Project As

To create a variation of a project without having to re-program everything from scratch, i.e. Change "Jones" project to "Smith" project:

1. Click "SAVE PROJECT AS" (Ctrl+S) from the File menu.
2. SINGLE CLICK on the project file name to 'Save As'.
3. Type in the new Project File Name (e.g. Smith) and click OK.
4. If there are no changes to the system (type of sources, brand of sources, zone configuration etc.) transfer the project. If there are any changes to be made, modify the new project and then transfer to the RS232IR.

Backing-Up Project Files

It is always wise to backup all project files to another hard drive, floppy disc or other storage media. It is recommended that each project be saved to a floppy disc and kept with each client's job files. To make backup copies, proceed as follows:

1. Open the hard drive icon from "My Computer" (usually drive C:) in Win 95/98/NT/2000/ME/XP. Open the DRAG460 folder, then the Projects folder.
2. Locate the project files. The files in the Projects folder will have .pja, .pjb, .pjc extensions. Copy all three.
3. Open a window for the backup drive and make a Projects folder for that drive.
4. Click and drag the files to be backed-up that are in the Projects folder on the main hard drive and drop them into the Projects folder in the backup drive.

NOTE 1: Project files can be relatively large, requiring up to 1 MB of space or more, depending on the complexity of your project. When backing up to 1.44 MB floppies, you may need one floppy for each Project.

NOTE 2: these file sizes can be reduced dramatically, if needed, by using a good file compression program, like Win Zip.

Using Backup Files

To use backup files at a later date, copy them back to the Projects folder in the DRAG460 directory (after un-zipping them, if previously Zipped). Proceed as follows:

1. Locate the Projects folder on the main and backup drives.
2. On the backup drive open the Projects folder and identify the files needed, with the proper extensions. Un-Zip them, if previously Zipped.
3. Click and drag these files from the backup drive and drop them into the Projects folder on the main hard drive.

Backing-Up SmartPad and Palette Files

The SmartPad and Palette folders in the DRAG460 directory contain all the files of learned individual IR commands and specific palettes that have been created for all projects. These should be backed up in the event of a hard drive failure, for transferring work to another computer, etc. Back-up these files to another hard drive, a tape drive or a floppy. Proceed as follows:

1. Open the hard drive icon from "My Computer" (usually drive C:) in Win 95/98/NT/2000/ME/XP. Open the Drag460 folder.
2. Locate the SmartPad and Pallets folders.
3. Click and drag (copy) the SmartPad and Pallets folders to the backup drive. These files are small enough to easily fit on one 1.44 MB floppy.
4. To use them at a later date, drag & drop them back into the Appropriate SmartPad or Palate folder on the main hard drive

NOTE: To avoid the potential loss of work, back up files frequently.

XANTECH CORPORATION
12950 Bradley Avenue, Sylmar CA 91342-3829
phone 818.362.0353 • fax 818.362.9506
www.xantech.com

Part No. 08901140 Rev A 02-11-2002