

INSTALLATION INSTRUCTIONS

480-95

Plasma Friendly Dinky Link IR Receiver

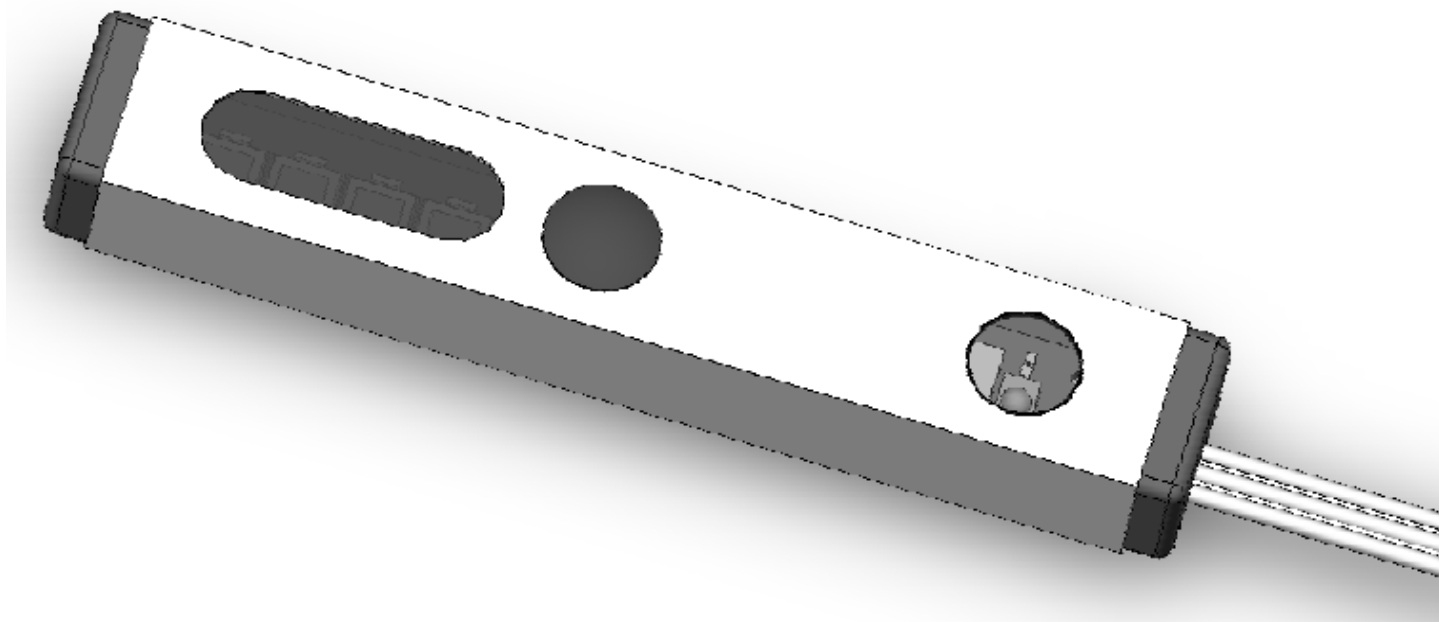

DESCRIPTION

The 480-95 is a Plasma Friendly version of the 480-00 series Dinky Link IR receivers. It is specifically designed to have greater immunity to plasma infrared interference and to have exceptional IR reception range. Besides showing great immunity to plasma emissions, the 480-95 (as well as all Xantech Plasma-Friendly Receivers) work well in the presence of Sunlight and Fluorescent lighting. Their *wide-bandwidth* reception allows them to be used with a much wider assortment of IR Controllable products that the competition assuring the 'job will get done' the first time around without un-wanted service calls.

These small IR receivers have been designed for mounting in very small spaces. They may be mounted under shelf edges, cabinet ledges, in-wall speakers, etc. anywhere an inconspicuous appearance is desired. The high sensitivity of these receivers allows placement behind speaker grilles and still receive IR commands up to 20 feet away. If longer range is necessary, a 3/8-inch hole must be drilled in the grille to allow unobstructed entry of the IR signal.

FEATURES

- Black, silver, and white color available.
- Works in normal 3-wire mode (12VDC, IR, GND).
- Red talkback LED for system verification.
- Improved Fluorescent light rejection (under most conditions) and rejection from LCD Displays.
- Includes 3-Terminal Block for easy extension of 7 foot ribbon cable.
- 7 units may be powered by one 781RG power supply.
- Normal Operating Power: +12VDC, 20mA.

Note: The 480-95 will not operate in 2-wire Phantom Power mode.

SPECIFICATIONS:

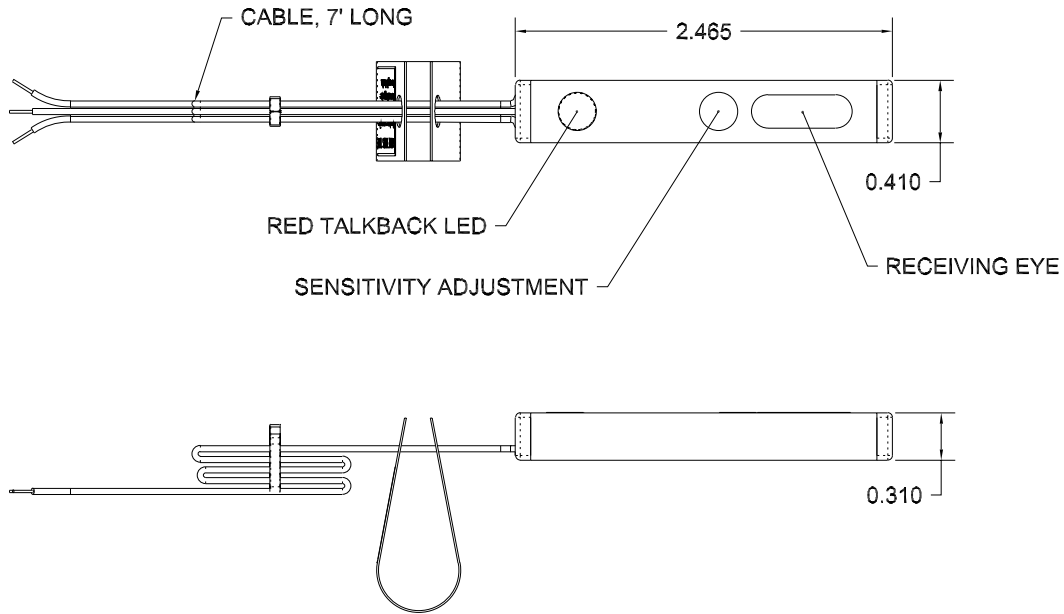

INSTALLATION

This unit is meant to be interfaced to Xantech Connecting Blocks, such as CB12, 789-44, 791-44, etc.

PLACEMENT

Placement of the IR Receiver does matter when used in the presence of a Plasma Display. Ideally it should be placed somewhere around the Display with the front of the receiver flush with the front of the Display. If the 480-95 needs to be placed in front of the display (such as on an adjacent side wall perpendicular to the display), make sure it is placed at a location at least 45 degrees off axis from the corners of the unit. The presence of Direct Sunlight and Fluorescent Lighting should not effect the reception of this unit.

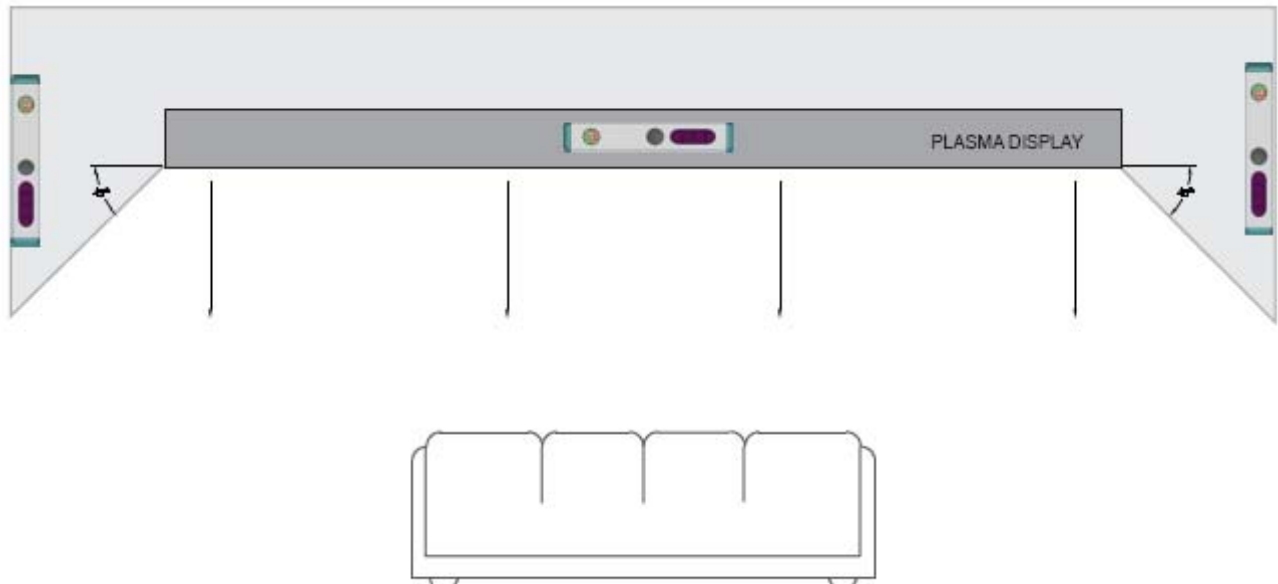

Note: Plasma interference can be reflected off of any item it comes into contact with approx. 3 feet from the front of the display. Keeping this in mind, make sure that the 480-95 is free of any obstruction that might reflect back in to the receiving eye.

Note: While this unit shows strong rejection to standard 50/60Hz 'ballasted' fluorescent lighting, it is still prone to interference from CFL style Fluorescent lighting.

MOUNTING

1. The 480-95 can be mounted to almost any surface using the included double-sided foam tape.
2. Connect proper wires to the +12VDC, GND, and IR to the Xantech Connecting Block.
3. For wire runs longer than 7 feet, use the included 3-terminal screw block to extend wiring runs.

SENSITIVITY ADJUSTMENT

The 480-95 is preset at the factory for optimal performance. However, some conditions may require fine tuning. Carefully remove the plastic circular cap to access the sensitivity potentiometer. The potentiometer is a highly precise and sensitive component, please be gentle when accessing and turning the potentiometer. The factory default is 12 o'clock position.

Clock-wise (CW)	Increase sensitivity
Counter Clock-wise (CCW)	Decrease sensitivity

APPLICATION WIRING

A typical system, with a 480-95, 781RG Power Supply and 283M Emitter plugged into a 789-44 Connecting Block, is shown in the figure below.

1. Wire the appropriate leads of the 3 conductor cable to the +12VDC, GND, and IR terminals on the 789-44 Connecting Block.
2. Plug in the 3.5 mm mono mini plug from any of the 282, 284, 283 and 286 series Emitters into the jacks labeled EMITTERS on the 789-44 Connecting Block and affix the opposite end of the IR Sensor Window of the controlled equipment.
3. Plug in the 2.1mm Coaxial power plug of the 781RG Power Supply (not included) into the jack labeled 12VDC on the 789-44 Connecting Block.
4. Plug the AC end of the 781RG Power Supply into an 'un-switched' 120VAC outlet.

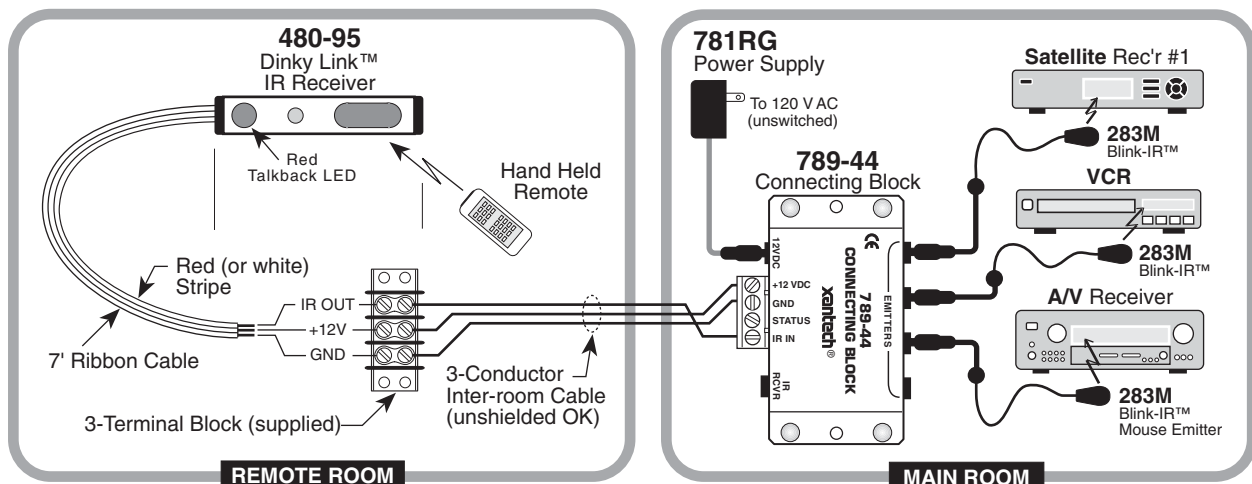

ADVANCED WIRING CONFIGURATION

480-95 may also be used in conjunction with other Xantech IR Receivers by simply wiring in parallel on a Connecting Block such as the 791-44 Amplified Block as shown in the figure below.

1. Connect all IR Receivers in parallel at the terminals of the connecting block as shown in the figure below.
2. Plug in the 2.1mm Coaxial power plug of the 781RG (or 782) Power supply (not included) into the jack labeled PWR on the 789-44CB.

Note: Up to 7 IR Receivers may be connected in parallel with a single 781RG power supply. If more IR Receivers or any Keypads are required, check total current requirements and increase power supply current rating accordingly; i.e. 782-00 – 1.2A Power Supply)

3. Plug in the Emitters 3.5mm mono mini plug (282, 284, 283 or 286 series) into the Emitter Outputs on the 791-44.

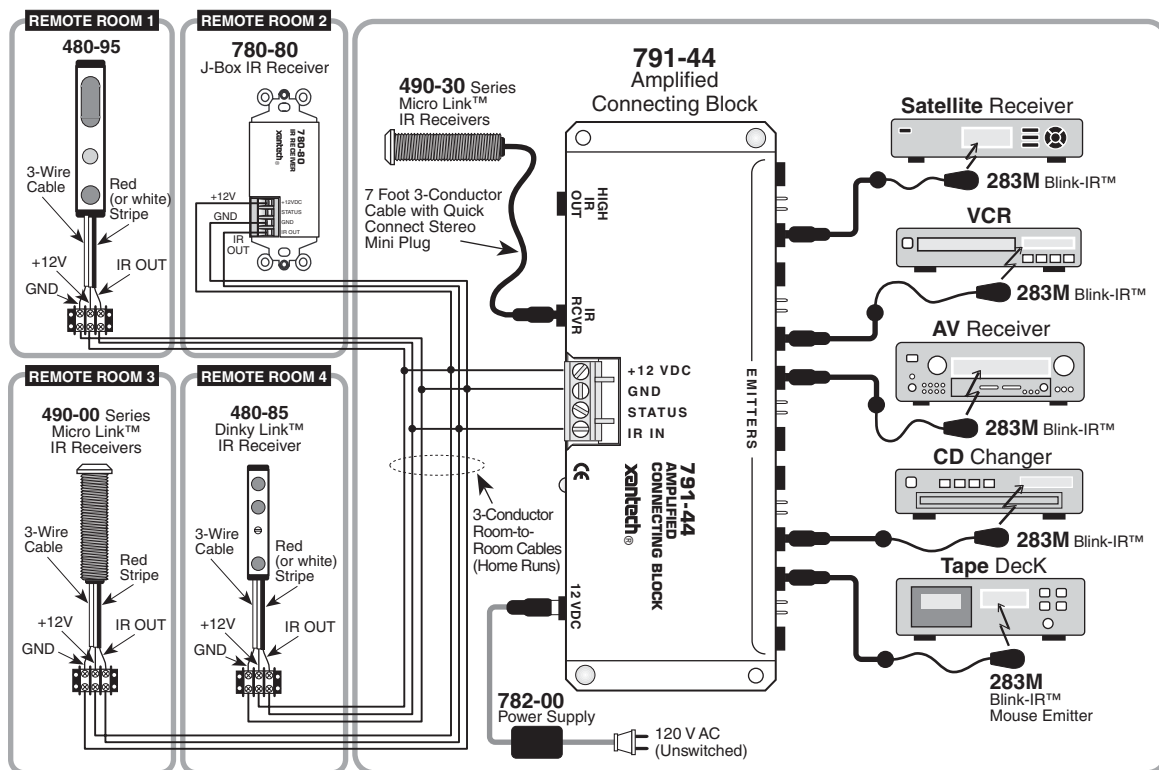

IR Troubleshooting Guide

NOTE: Due to the many variables in a given installation, the troubleshooting countermeasures you will have to take may vary from job to job. Each installation is different due to the number of IR receivers in use, length of wire runs, type of wire, amount of ambient IR noise present, etc.... Therefore, your countermeasures for a particular job will range from nothing at all, to any combination of the solutions listed below.

Model #'s IR Receivers: Model #'s 291, 480, 490, & 780 Series

Symptom #1: DIM or NO Talk Back LED during IR Reception or reduced operational range

	<u>Cause:</u>	<u>Solution</u>
1.	Weak Batteries in Transmitting Remote.	Replace batteries.
2.	Bad Emitter or no emitter plugged into connecting block.	Test emitter and verify wiring.
3.	Signal wire between IR Receiver and the Connecting Block is open.	Recheck wiring.
4.	Power Supply not putting out proper voltage.	Verify supply is a 12VDC regulated supply reading between 11.5 to 13VDC under load. Should be using Power Supply Model 781RG (12VDC Regulated, 200mA) or 782-00 (12VDC Regulated, 1.2A)
5.	Output from the IR receiver/connecting block is connected to a high impedance IR input jack on a component.	If you are using a passive connecting block, such as a 789-44, and the system is not working, try the amplified connecting block, model 791-44. Put one of the small plastic case jumpers supplied with the block on the pins next to the emitter jack. This will provide the IR-in jack on the component with a hotter signal.
6.	IR Receiver is inoperable.	Replace Receiver.
7.	(XTRALINK Only) RF Amplifier is being used on same COAX Line anywhere between the Coupler (CPL94) and Injector (INJ94).	Need to use a Bypass Kit (model BYPASS94 Kit) to route the IR control signals around the amplifier(s).

Symptom #2: TB LED on IR Receiver (and/or Emitters) Dimly lit or flickering

	<u>Cause:</u>	<u>Solution</u>
1.	Signal and ground wires are reversed or shorted either at the connecting block or IR receiver.	Recheck your wiring.
2.	Defective emitter.	Replace Emitter
3.	Relatively high levels of ambient noise . This can be due to any of the following: Sunlight, florescent Lighting or Plasma Displays.	In this case use either a SUN filter (SUN480, SUN490, SUN780), or any of our 'CFL Friendly' IR Receivers (291-80, 480-80, 780-80). For Plasma Interference use the 490-90 or 780-90 'Plasma Friendly' IR Receivers. These can also be used in direct sunlight and in the presence of 'tube style' florescent lighting.
4.	EMI induced noise. This can be due to light dimmer controls or other radiating electronic devices (PC's or any poorly shielded electronic device).	Reposition IR Receiver and/or cabling away from emitting device. You can also place a 470Ohm resistor in parallel with the IR Signal and GND connections on the connecting block. This will also help alleviate any stray capacitance in the cable.
5.	Plasma Interference	Use a 490-90 Plasma 'Friendly' IR Receiver. If already using a 490-90 unit, please note the Plasma interference can be reflected off of any item it comes into contact with within approx. 3ft. From the front of the display. Keeping this in mind, make sure that the 490-90 is free from any obstruction that might reflect back into the receiving eye.

Symptom #3:TB LED on IR Receiver (and/or Emitters) on solid

	<u>Cause:</u>	<u>Solution</u>
1.	Plasma Interference	Use a 490-90 Plasma 'Friendly' Receiver. If already using a 490-90 unit, please note the Plasma interference can be reflected off of any item it comes into contact with within approx. 3ft. From the front of the display. Keeping this in mind, make sure that the 490-90 is free from any obstruction that might reflect back into the receiving eye.
2.	Voltage and Ground wires are reversed at the connecting block or IR Receiver	Recheck your wiring.
3.	Relatively high levels of ambient noise . This can be due to any of the following: Sunlight, florescent Lighting or Plasma Displays.	In this case use either a SUN filter (SUN480, SUN490, SUN780), or any of our 'CFL Friendly' IR Receivers (291-80, 480-80, 780-80). For Plasma Interference use the 490-90 or 780-90 'Plasma Friendly' IR Receivers. These can also be used in direct sunlight and in the presence of 'tube style' florescent lighting.
4.	EMI induced noise. This can be due to light dimmer controls or other radiating electronic devices (PC's or any poorly shielded electronic device).	Reposition IR Receiver and/or cabling away from emitting device. You can also place a 470Ohm resistor in parallel with the IR Signal and GND connections on the connecting block. This will also help alleviate any stray capacitance in the cable.
5.	Power Supply not putting out proper voltage.	Verify supply is a 12VDC regulated supply reading between 11.5 to 13VDC under load.

Symptom #4: TB LED on IR Rec. blinks but 283M or 286M 'Blink' style Emitters do not

	<u>Cause:</u>	<u>Solution</u>
1.	There may be a short, such as a staple driven through the Signal and GND wires of the IR Receiver and/or the emitter.	Recheck your wiring.
2.	Emitter may be shorted internally	Replace Emitter or use TEST EMITTER to check circuit.
3	(XTRALINK Only) TV on same splitter with no IR Receiver installed	Place a DC Blocker (Model 203-00) on any TV Leg without IR Receiver

Symptom #5: Intermittent IR control (I.e. buttons on remote need to be pressed multiple times)

	<u>Cause:</u>	<u>Solution</u>
1.	Plasma Interference	Use a 490-90 Plasma 'Friendly' Receiver
2.	Relatively high levels of ambient noise . This can be due to any of the following: Sunlight, florescent Lighting or Plasma Displays.	In this case use either a SUN filter (SUN480, SUN490, SUN780), or any of our 'CFL Friendly' IR Receivers (291-80, 480-80, 780-80). For Plasma Interference use the 490-90 or 780-90 'Plasma Friendly' IR Receivers. These can also be used in direct sunlight and in the presence of 'tube style' florescent lighting.
3.	Long Wire Runs – shielded wire typically of 100 feet (30 meters) or longer causes a filter effect due to accumulated capacitance of the wire. Intermittent, or no IR control, could actually be because of the longer wire runs.	Putting a 470-ohm resistor in parallel at the connecting block between signal and ground will effectively discharge the capacitance of the wire. This will allow the signal to travel farther on shielded wire. Adding a resistor between the input and ground of the connecting block will drop the IR level down somewhat. Passive connecting blocks, such as the 789-44, may not have enough signal output for consistent control of the equipment. You may have to upgrade to an amplified connecting block to bring the IR level back to normal. In these cases, the 791-44 would be an ideal connecting block for single zone systems while the 795-20 would work best for a 2-4 zone system.

Symptom 6: Emitters function but some (or all) components do not respond.

	<u>Cause:</u>	<u>Solution</u>
1.	Emitter placement is incorrect.	Reposition the Emitter so that it is directly over the components sensor window. Consult the components owners manual of the unit for the exact location of the IR Sensor Window.
2.	Emitter placement is correct but the signal is overpowering the unit or there is bleed-through from other emitters close by.	Reposition the Emitter to a position that is suitable for the unit. Use a 283 or 286M Blink style emitter (they have a lower output than non-blink emitters 282 and 284M). If the components do not need to be controlled directly without an IR Repeater system (components are located in an equipment closet), place a Mouse Emitter Shield cover over the Emitter (PN#MS1). The rounded (non-stick) side of the emitter is a hi-output side and can reflect off other devices and overpower some components IR Sensors. If using a CB12 connecting block, try a 789-44 connecting block. This has a series resistor at the output, which will limit current to the Emitter.
3.	Using a CFL-Friendly IR Receiver (291-80, 480-80, or 780-80) and trying to control a unit with a carrier frequency greater than 40kHz (i.e. RCA DSS, Scientific Atlanta, Jerald, and General Instruments Cable or DSS Set Top Boxes).	If you are using the 291-80 or 780-80 CFL Friendly receiver, locate the Carrier Frequency Adjustment on the unit and using a small blade screwdriver, (3/32" blade width max.) rotate the adjustment for best performance of all the units in the system. Note: The 480-80 version does not have this feature; you will either need to change the unit to a 291-80, 780-80 or the 490-90. The 490-90 is a wide band unit and will not require any frequency adjustment.

Symptom #7: Absolutely No Functionality (How to determine which component is at fault)

Step:	Component to Test	Instructions
1.	Verify Power Supply	With a Multimeter, measure the DC Voltage of the supply while it is connected to the Connecting Block. Put the Negative lead of the meter on the terminal marked GND and the Positive Lead on the terminal marked 12VDC (or V). You should get a reading between 11.5VDC and 13.0VDC. If not, remove the supply from the Connecting block and measure again this time directly on the 2.5mm Coaxial plug. If it reads between 11.5VDC and 13VDC, power supply is most likely good. Reconnect to the Connecting Block and proceed to step 2. NOTE: In most cases this will indicate the supply is good but in some cases the supply can still be bad (i.e. reads good when not plugged in but may not be able to handle the current load of the system.)
2.	Verify Emitter. (283M or 286M Blink Style ONLY)	Remove the power supply from the connecting block and all Emitters from the output. Place a jumper wire on the connecting block between IR and +12v. Reconnect the Power Supply and one emitter. The Emitter should Light bright and solid. Repeat for all emitters.
3.	Verify Emitter. (282M or 284M NON Blink Style)	Use a diode tester to verify proper Emitter operation. Remove Emitter from Connecting Block. Place the Positive Lead of the tester on the TIP of the Mono Mini Plug and the Negative Lead on the Shield of the Mono Mini Plug. Meter should read a voltage. When the leads are reversed (Positive lead on Shield and Negative lead on TIP) you should not get any voltage reading at all.

4.	Verify IR Receiver.	Remove the power supply from the connecting block and all Emitters from the output. Place a jumper wire on the connecting block between IR Signal and GND. Reconnect the Power Supply. With a known good hand-held remote, shoot a constant IR Command at the receiver and verify the TB LED on the Receiver lights.
----	---------------------	--



Xantech Corporation
13100 Telfair Avenue, 2/F
Sylmar, CA 91342

Phone: (818) 362-0353, Fax: (818) 362-9506

Instructions, 480-95 © 2006 Xantech Corporation

This document is copyright protected. No part of this manual may be copied or reproduced in any form without prior written consent from Xantech Corporation.

Xantech Corporation shall not be liable for operational, technical, or editorial errors/omissions made in this document.

Document Number 08905099 Rev B