

INSTALLATION INSTRUCTIONS

172-94 XTRA LINK® 2 REMOTE CONTROL EXTENSION SYSTEM

The Xtra Link 2 system provides full remote control operation of a satellite receiver, cable box or VCR from a second room by sharing the coaxial cable connecting your video equipment to this second room's TV.

The 172-94 Xtra Link 2 consists of the following supplied parts (**Fig.1**):

1. **One 291-00 IR Receiver.** It is placed at the remote room location to receive IR signals from the handheld remote controller.
2. **One INJ94 Injector.** This unit, located in the Remote Room, injects the remote control signal into the room-to-room coaxial cable (along with the TV signal) and passes it to the CPL94B Coupler in the Main room. It also provides quick connection of the 291-00 IR Receiver and 781C-00 Power Supply cables.
3. **One CPL94B Coupler.** Located in the Main Room, this Coupler extracts the remote control signal from the coaxial cable and passes it to the emitters that control your IR remote controlled audio/video source components. Two emitter jacks are provided for control of up to four components.
4. **One 282M high output emitter and one 283M Blink-IR™ emitter.** These permit a control of two IR remote controlled components. The visible output of the **283M** allows it to also be used for **troubleshooting**.
5. **Two short coaxial cables.** One connects the TV signal source to the CPL94B Coupler in the Main Room. The other connects the INJ94 Injector to the TV in the Remote Room.
6. **A 781C-00 Power supply.** This plugs into an unswitched 120V AC outlet to provide power to the 291-00 IR Receiver.

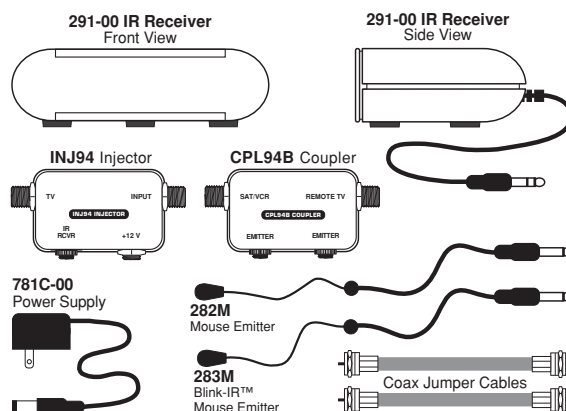

Fig. 1 172-94 Xtra Link 2 System Parts

CONNECTIONS:

The Xtra Link system uses the coaxial cable that carries the TV RF signal from the source equipment in the main room to the remote room, to send the IR control signals back to the source equipment. The coaxial cable may be up to one mile in length.

If you already have a coaxial cable connecting your video equipment with a remote room, your current hookup should be similar to **Fig. 2**. If it isn't, run a single length of RG59 or preferably RG6 cable from the Main Room to the Remote Room.

NOTE: If RF amplifier(s) are used anywhere in the line of coaxial cable between the CPL94B Coupler and the INJ94

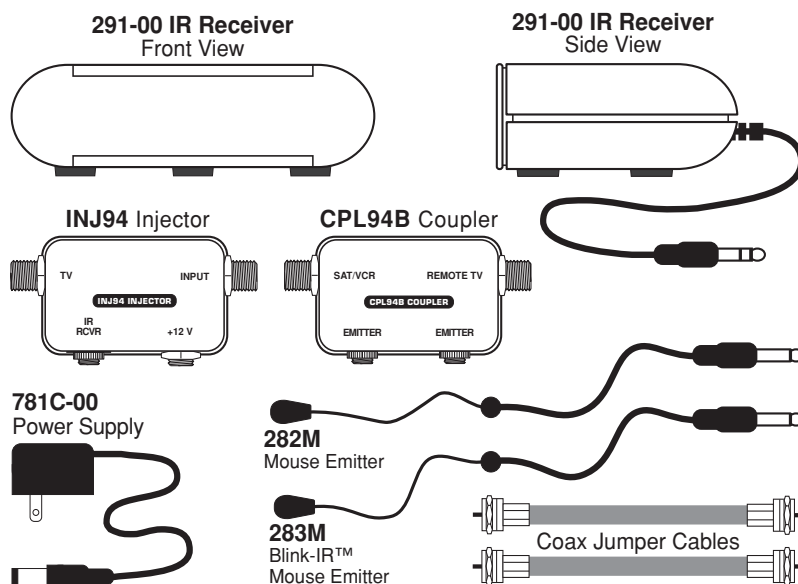

Fig. 2 Basic System Without Xtra Link

Injector, you must use a Xantech BYPASS94 KIT to route the IR commands around the amplifier(s). When using more than one Xtra Link for more rooms, be sure the RF splitters you use are DC passing types, such as Xantech Models 200-00 (2-way) and 202-00 (4-way). Refer to **Fig. 4**.

INSTALLING THE 291-00 IR RECEIVER:

Insert the cable mini plug attached to the 291-00 into the jack marked "IR RCVR" on the INJ94 Injector. Refer to **Fig. 3**.

Plug the 781C-00 Power Supply cord into the jack marked "+12 V" on the INJ94 Injector. Plug the 781C-00 into a 120 VAC unswitched outlet after you have made all other connections.

Position the 291-00 IR Receiver so that the infrared beam from the handheld remote control has a direct view to the front of the unit, within 20 feet.

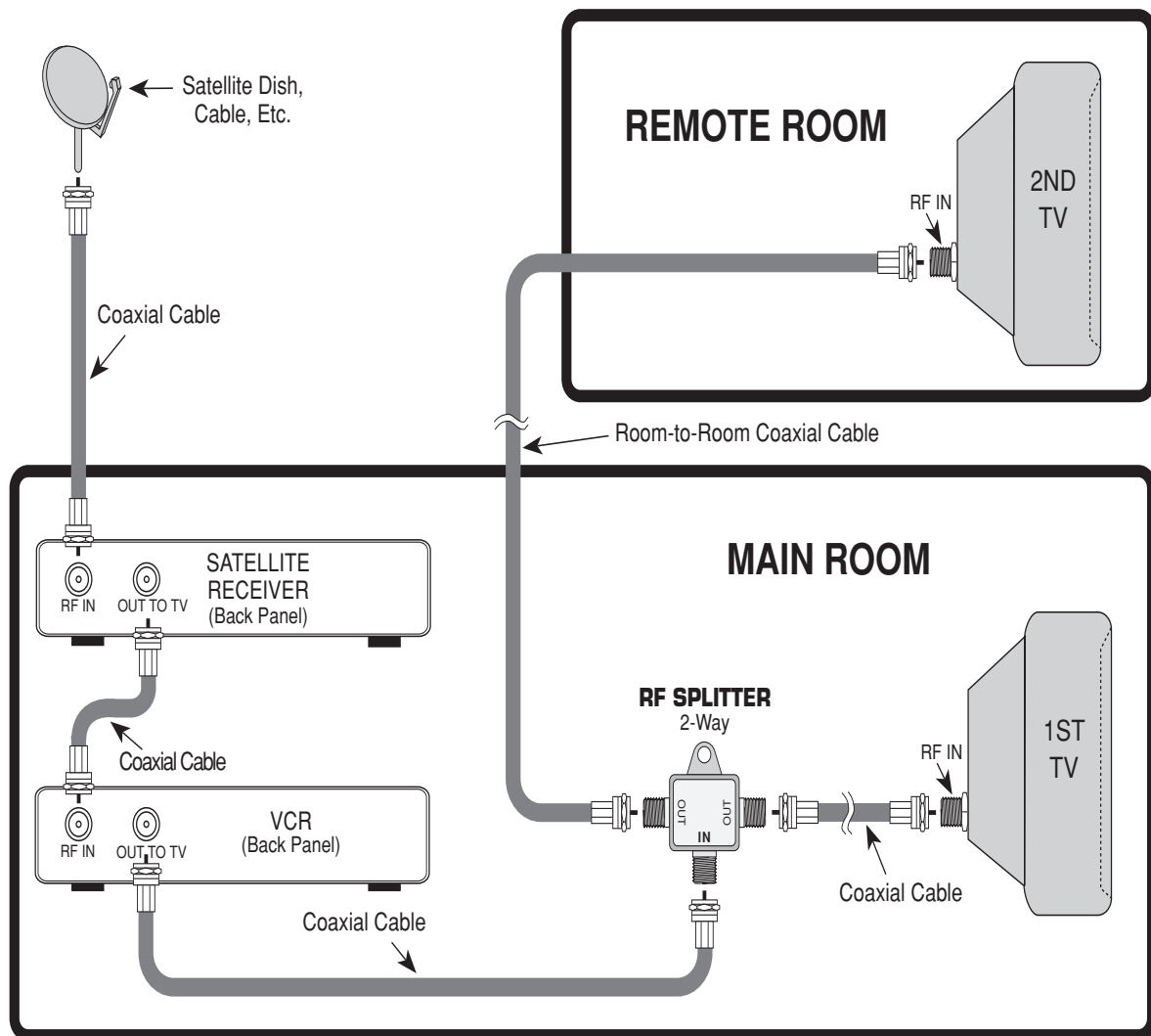

Fig. 3 Basic Xtra Link Hookup

INSTALLING THE INJ94 INJECTOR:

Connect one of the two short coaxial cables between "TV" on the INJ94 Injector and "RF IN" on the TV in the Remote Room. Connect the room-to-room cable to "INPUT" on the INJ94 Injector.

INSTALLING THE CPL94B COUPLER:

Connect the other short coaxial cable between "SAT/VCR" on the CPL94B Coupler and the RF splitter. Connect the room-to-room cable to "REMOTE TV" on the CPL94B Coupler.

Make the remaining connections from the RF splitter to the "OUT TO TV" on VCR, the RF splitter to the local TV, etc., as shown in **Fig. 3**.

NOTE: If your main room TV has A/V input jacks, you may connect the VCR and Satellite Receiver with A/V patch cords instead of using the RF IN jack on the TV and the RF splitter. Refer to **Fig. 3** for typical connections.

INSTALLING THE IR EMITTERS:

Plug the supplied emitters into the jacks marked "EMITTER" on the CPL94B. Next, remove the paper backing exposing the adhesive surface of each emitter. Press the adhesive side directly into place over the center of the infrared sensor "window" on the **front panel** of the satellite receiver, VCR, etc.

NOTE: It may not be possible to place emitters on the sensor of some products (such as RCA DSS receivers). In such cases, use the high output 282M emitter placed close to the sensor or on a nearby shelf, etc. (within 6 inches).

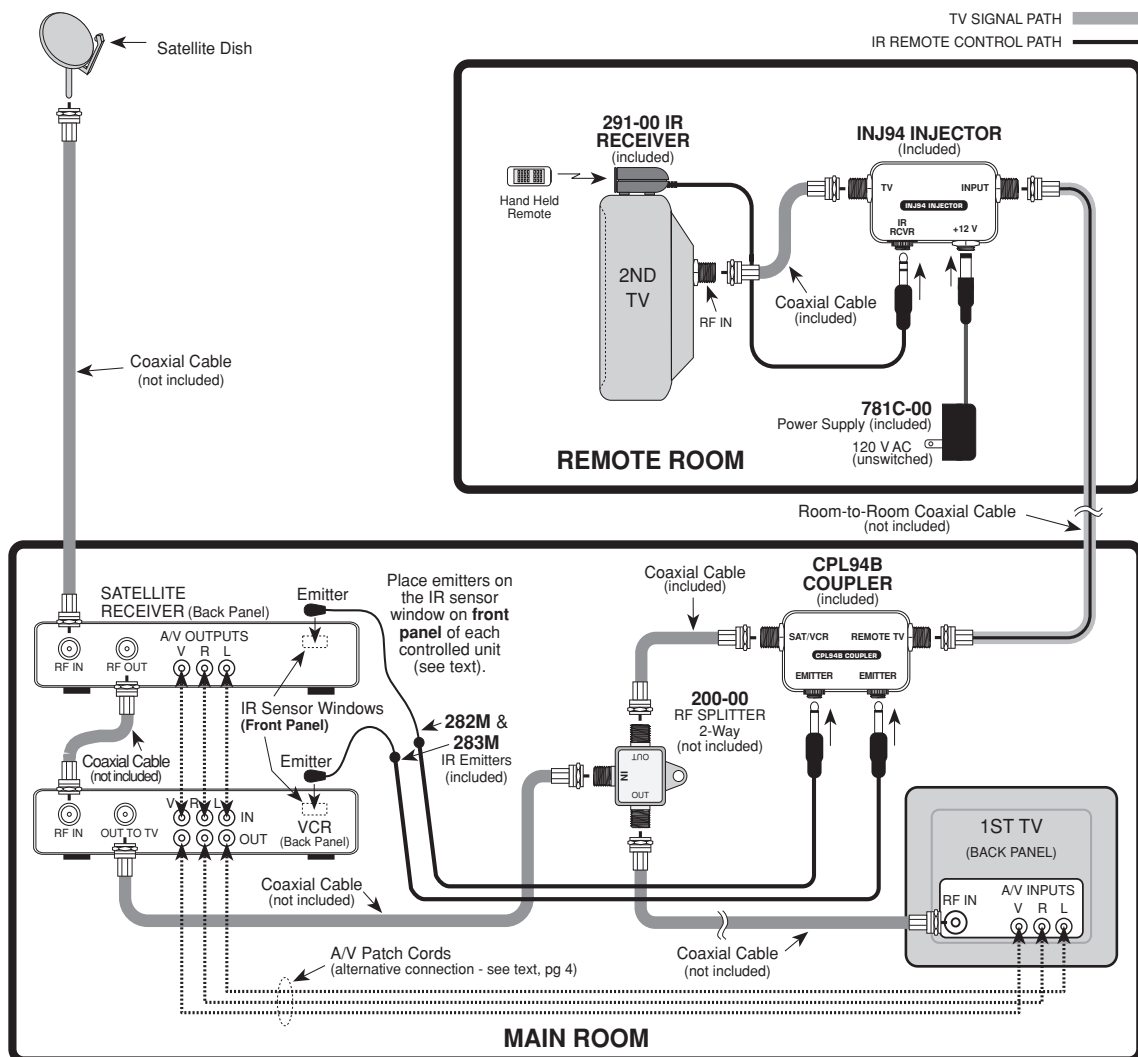

Fig. 4 Advanced Multiroom Hookup

OPERATION

When you use the system, a red LED on the front of the 291-00 and the 283M emitter will flash when receiving your infrared commands.

The maximum usable distance between your IR remote and the 291-00 Receiver will vary for each remote and might be shorter than when directly used in the room containing the satellite receiver or other IR controlled devices.

The 172-94 system may be left on continuously as it does not affect the normal operation of the remote controlled device(s) and consumes very little energy.

NOTE: Although the emitters appear dark to the eye, they are transparent to infrared. Positioning them directly over the infrared window(s) of the component(s) will not block direct IR control from your handheld remote.

ADVANCED MULTIROOM HOOKUP

Fig. 4 shows an advanced system using two Xtra Links in a multiroom installation. Except for the addition of a 2-way DC passing RF splitter (such as the Xantech Model 200-00), the connections are essentially the same. To obtain just the parts needed for the 3rd room, order the 172-94X Xtra Link2 expansion kit. (Note: The expansion kit does not include a 2-way DC passing RF splitter. The splitter must be ordered separately).

TROUBLESHOOTING

In some cases, the 291-00 IR Receiver may have to be moved to a different location if the unit is picking up interference. This interference may, in severe cases, prevent the system from working.

Common sources of interference are:

- RF radiation from the TV set on which the 291-00 IR Receiver may have been placed.
- Direct or reflected sunlight.
- Fluorescent, Compact Fluorescent, Neon, Neon Art, Halogen lights or light dimmers.
- Active Infrared security systems.

You can confirm the source of the interference by temporarily turning off or isolating the 291-00 Receiver from such sources. Then check to see if the 291-00 operates the satellite receiver or other components.

If the 291-00 still does not work, reposition the Emitters. They may not be located directly over the component's infrared receiving sensor. Consult the owner's manual of the unit or the manufacturer for the exact location of the infrared "window" sensor.

If you have one or more TV sets in rooms where you **do not** have Xtra links and they share the same DC passing RF splitter, you must use **DC Blockers** (Xantech Model **203-00**) connected in the coaxial line to each of these TV sets. This is a **must** to prevent such TV sets from "shorting out" the IR control signal.

IMPORTANT: For installations involving more than two remote rooms, use the services of a competent professional audio/video installer experienced in infrared remote control systems.