

A PRODUCTION RELEASE PER ECO# 4058

-./% #0 11\$ PRINTING
2\$ BLACK
- 3 4 \$ 20# MEAD BOND, WHITE
4 4 /\$ NONE
'4 41" 45 \$ 8.5" X 11"

xantech

!
"# \$!!% & %
' (\$!!% & % &

- * % +
- * % +
- * _____ ,

INSTRUCTIONS,49095

R. Seegull 05/19/04

1-1 A 08901485 A

) _____ ' 5

INSTALLATION INSTRUCTIONS

MODEL 490-95 MICRO LINK™ “PLASMA FRIENDLY” INFRARED RECEIVER

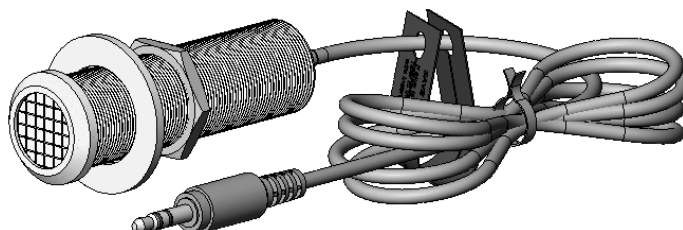

TABLE OF CONTENTS

INTRODUCTION	1
Features	1
Specifications	1
INSTALLATION	2
Placement	2
Mounting.....	2
Application Wiring.....	3
Advanced Wiring Configuration.....	3
3.5mm Mini Plug Pinout.....	4

INTRODUCTION

The **490-95** is designed to reject interference from **Plasma** Displays from entering the IR signal line. These Small IR Receivers are intended to be mounted in panels, doors, cabinets, etc. for control of A/V equipment behind closed doors or any IR Repeater System that is in close proximity of a **Plasma** or **LCD** Displays. Modeled after the original 490-90, the 490-95 offers the same features as its predecessor but in a smaller mounting frame.

FEATURES

- Small size; mounts in 3/4" diameter hole. 2 3/4 inches deep (70mm)
 - Quick-Connect 3.5mm Stereo Mini Plug on 7ft. (213.36cm) cable for direct plug-in to **Xantech** Connecting Blocks
 - Works in normal 3-wire mode (12VDC, IR, GND)
 - Green Talkback LED for System Verification
 - Improved Fluorescent Light rejection (under most conditions) and rejection from LCD Displays
 - Can be used in Direct Sunlight
 - RF Grid included for EMI interference reduction
 - Includes CB12 Connecting Block for easy connection and extension of 7' ribbon cable
 - 7 units may be powered by one 781RG power supply
- Note:** The 490-95 will not operate in 2-wire **Phantom Power** mode

SPECIFICATIONS

- Infrared modulation frequency bandwidth: 30 - 100 kHz
- Reception range: up to 55 feet (17M), depending on local conditions
- Reception angle: 55 degrees off axis for 50% range reduction
- Cable requirements: 3-conductor. Use 24 gauge up to 200' (61M), 22 gauge up to 600' (182.5M), 20 gauge up to 1000' (305M), 18 gauge up to 2000' (610KM) -- unshielded OK
- Maximum transmission length: One mile using 18 gauge wire (1.6KM)
- Maximum current output: 100 mA
- Dimensions: 0.75" diameter x 2.75" deep (19mm x 70mm)
- Power requirements: 12 volts DC @ 20 mA

INSTALLATION

These units, equipped with a 7-foot cable and 3.5 mm stereo mini plug, are intended to be plugged directly into the "IR RCVR" or "AUX" jack on Xantech Connecting Blocks, such as the CB12(included), CB60, 789-44, 791-44, etc. The 490-95 should be used in installations where the connecting block is within reach of the 7-foot cable -- such as when installing the 490-95 in a cabinet where the controlled equipment is behind closed doors.

PLACEMENT

Placement of the IR Receiver does matter when used in the presence of a Plasma Display. Ideally it should be placed at areas around the Display with the front of the receiver flush with the front of (or set back from) the Display. If the 490-95 needs to be placed in front of the display (such as on an adjacent side wall perpendicular to the display), make sure it is placed at a location at least 45 degrees off axis from the corners of the unit – see **Figure 1**. The presence of Direct Sunlight and Fluorescent Lighting should not effect the reception of this unit.

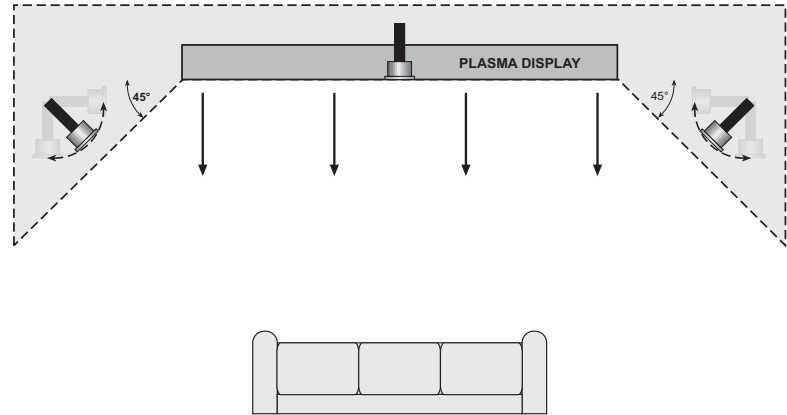

Figure 1 – 490-95 Placement

Note: Plasma interference can be reflected off of any item it comes into contact with within approx. 3 ft. from the front of the display. Keeping this in mind, make sure that the 490-95 is free of any obstruction that might reflect back into the receiving eye.

Note: While this unit shows strong rejection to standard 50/60Hz 'ballasted' fluorescent lighting, it is still prone to interference from CFL style Fluorescent lighting.

MOUNTING

1. Drill a 0.75" (19mm) hole in any flat surface, such as a cabinet panel.
2. Pass the lead and the body of the 490-95 through the hole.
3. Secure from the rear with the Washer and Nut (all supplied) as shown in **Figure 2a**. Be sure not to over-tighten nut.

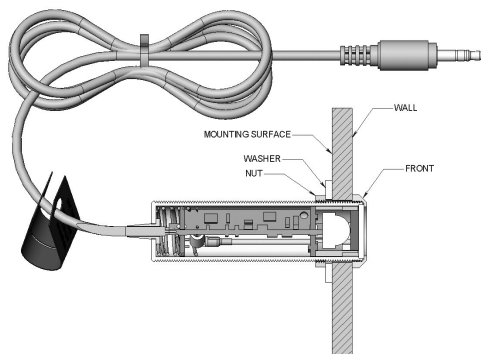

Figure 2a – 490-95 Features

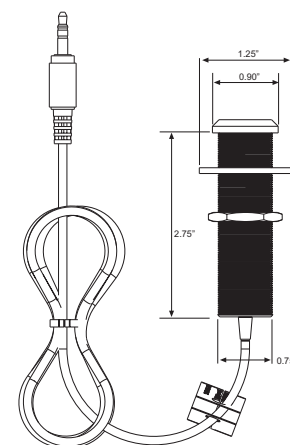

Figure 2b – 490-95 Dimensions

APPLICATION WIRING

A typical system, with a 490-95, 781RG Power Supply and 283M Emitter plugged into a 789-44 Connecting Block, is shown in **Figure 3**:

1. Plug in the 2.1mm Coaxial power plug of the 781RG Power Supply (not included) into the jack labeled 12VDC on the 789-44 Connecting Block.
2. Plug the AC end of the 781RG power Supply into an 'un-switched' 120v AC Line outlet.
3. Plug the 3.5mm stereo mini plug from the 490-95 into the IR RCVR input on the 789-44 Connecting Block
4. Plug in the Emitters 3.5mm mono mini plug such as any of the 282, 284, 283 and 286 series into the jacks labeled EMITTERS on the 789-44 and affix the opposite end to the IR Sensor Window of the controlled equipment.

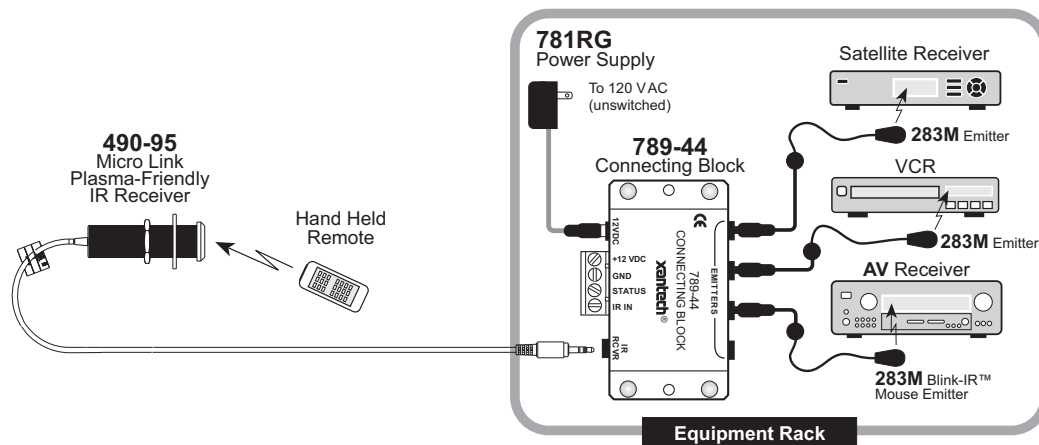

Figure 3 - Typical System Layout using 490-95, 789-44, 781RG, and 283M Emitters

ADVANCED WIRING CONFIGURATION

490-95 may also be used where the 7-foot lead is not long enough. In this case, simply use the CB12 Connecting Block as a "break-out" block. In **Figure 4**, a 490-95 is extended down to a 789-44 Connecting Block and combined with other Xantech IR Receivers.

1. Plug the 3.5mm stereo mini plug from the 490-95 into the IR RCVR input on the CB12 Connecting Block.
2. Using 3-Conductor wire (refer to **Specifications** section for proper Wire Gauge) connect the terminals labeled **V G S** of the CB12 to the terminals labeled **+12VDC**, **GND**, and **IR IN** on the 789-44 Connecting Block (or other)
3. Plug in the 2.1mm Coaxial power plug of the 781RG (or 782) Power Supply (not included) into the jack labeled PWR on the 789-44CB.

CAUTION! Do not plug in a 781RG or any other Power Supply into the CB12 when using in a "break-out" configuration. This will put 2 supplies in parallel and possibly damage your equipment. If a 'local' emitter is needed on the CB12, see Step 5 below.

4. Plug in the Emitters 3.5mm mono mini plug such as any of the 282, 284, 283 and 286 series into the Emitter Outputs on the 789-44.

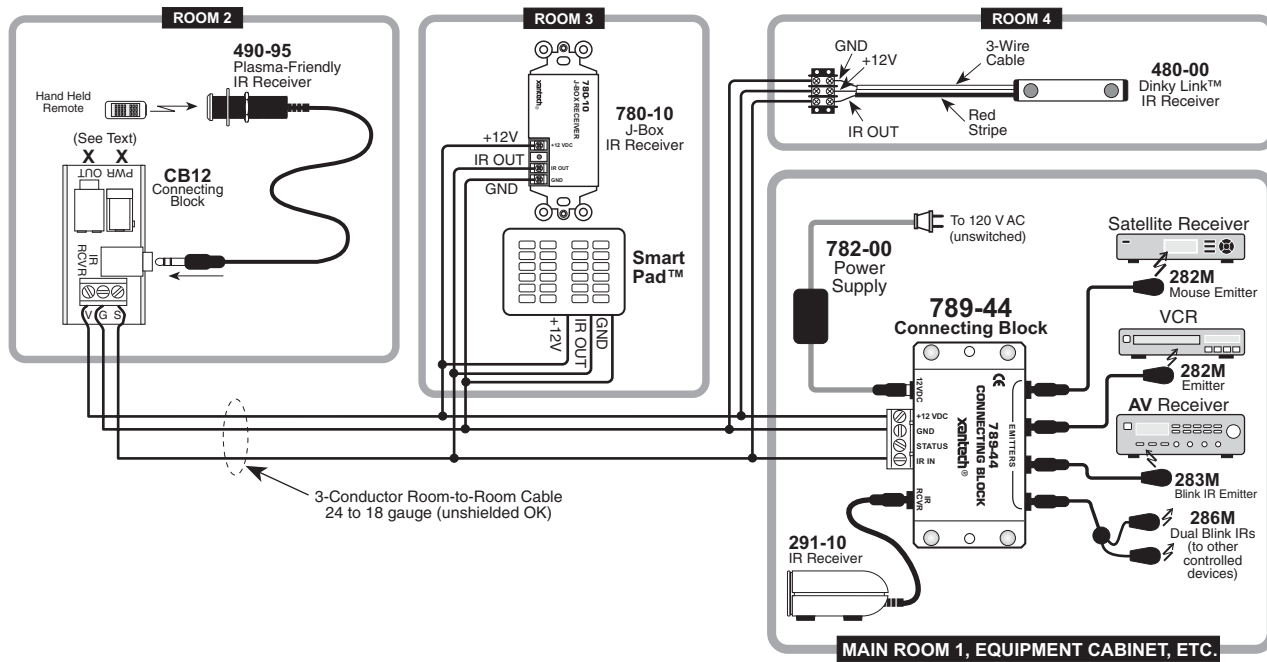

Figure 4 - Advanced Wiring Configuration using 490-95, CB12, 789-44, 781RG and multiple 286M's

5. If a local Emitter is needed on the CB12, you will need to place a 470 Ohm Resistor in Series with the Signal Output on the CB12. To Wire in this fashion:
 - a. Cut a standard Mouse Emitter (282M or 283M) approximately 12 inches from the 3.5mm Mono Mini Jack. You will now have 2 cables; one with a 3.5mm Mono Mini Jack and one with the Mouse Emitter.
 - b. Wire the 2 leads of the Mono Mini Jack side to a terminal Strip.
 - c. On the Terminal Strip, opposite the lead with the White Stripe (Signal) connect one side of the 470 Ohm Resistor.
 - d. Wire the other side of the resistor to the lead with the White Stripe on the Mouse Emitter.
 - e. Connect the Black Wire of the Mouse Emitter to the Terminal Strip opposite the Black Wire (GND) from the 3.5mm Mono Mini Jack.

This will keep the proper load balance and prevent miscommunication with the Emitters on the 789-44 CB.

3.5MM MINI PLUG PINOUT

There might be times when the 490-95 needs to be wired directly to a Terminal Block. In that case you will need to cut off the 3.5mm jack and wire according to **Table 1**.

Table 1 - 490-95 Connector Pin-Out

PLUG	CABLE LEADS	CIRCUIT ITEM
TIP	WHITE	IR OUT
RING	BLACK	GROUND
SLEEVE	RED	+12V

CAUTION: With any of these systems, be sure the 781-RG Power Supply is plugged into an un-switched AC outlet. This maintains the 490 system in "stand-by" operation so that power-on commands can be sent to the controlled equipment.

XANTECH CORPORATION
 13100 Telfair Avenue, Sylmar CA 91342-3829
 phone 818.362.0353 • fax 818.362.9506

Part No. 08901485 Rev A 07-22-04